



Introduction

A motion sensor (passive-infrared or PIR) detects movement within a specific area by sensing the infrared energy emitted from a body as it moves across the sensor's field of view. When this motion is detected, the sensor transmits an alarm signal to the control panel.

Use a motion sensor to protect locations where door/window sensors are impractical or not needed. For example, use a motion sensor to protect large areas or open floor plans. Motion sensors also provide backup protection for door/window sensors.

Alarm Processing:

The RF-ARPIR-345-NN utilizes advanced signal processing, and a top-quality infrared detector. Next, a patented modern DSP ASIC directly converts the infrared detector signal into digital form, for best reliability and stability.

Pet Immunity:

The RF-ARPIR-345-NN is designed to allow the presence of pets (up to 22 lbs.) without signaling an alarm. It includes a special micro-element lens array that produces much stronger optical signals for humans than for pets 22 lbs. or lighter.

NOTE: Pets come in many varieties. Some pets (especially larger ones with very short hair), even if lighter than 22 lbs. may produce enough infrared radiation to cause alarms. RF-ARPIR-345-NN users are strongly advised to test the sensor with their own pets, in order to verify that the detector will not signal an alarm when their pets are moving within its fields of view.

Installation

If you have a pet, this PIR was designed for indoor use in the presence of pets having a combined weight of up to 22 pounds.

The following installation guidelines must be met to provide this false alarm immunity.

- The sensor must be incline-mounted on a wall surface or incline mounted in a corner at a mounting height of 7.5 feet (2.3 m)
- The sensitivity switch must be set to Standard.

The pet must not be allowed to climb on objects such as furniture, boxes, etc. within the field of coverage

- Room temperature must be kept between 60° and 120° F (16° and 49° C).
- Do not aim the sensor at windows, fireplaces, air conditioners, area heaters, forced air heating vents, or place it in direct sunlight.
- Windows should be closed in any area which has an armed motion sensor.
- Position the sensor to protect an area where an intruder would be most likely to walk across the detection pattern.
- Mount the motion sensor on a rigid surface which is free from vibrations.
- Mount the sensor permanently on a flat wall or in a corner. Do not set it on a shelf.
- Mount the motion sensor on an insulated, outside wall facing in.
- Position the sensor so it faces a solid reference point, like a wall. If possible, locate sensors within 100 feet (30.5 m) of the panel. While a transmitter may have a range of 500 feet (152 m) or more out in the open, the environment at the installation site can have a significant effect on transmitter range. Sometimes a change in sensor location can help overcome adverse wireless conditions.
- Do not mount the sensor near duct work or other large metallic surfaces which may affect the RF signals (see "Walk Testing" on page 2). Actual acceptable transmitter range should be verified for each installation.

Mounting Location

A. Wall mounting:

1. Sensor base fastened flat on vertical wall (± 2 degrees).

B. All mounting:

1. Height = 2.3 m or 3m above floor of monitored area.
2. Clear line-of-sight from sensor to monitored area

Note: glass will block sensor's view.

3. Wall temperature similar to walls/floor of monitored area.
4. Sensor aimed away from windows and reflected sunlight.

5. Sensor aimed away from heaters or heater/cooler outlets.
6. Sensor aimed so that likely intruder paths cross three views.

Top view of lens coverage (measured in feet)

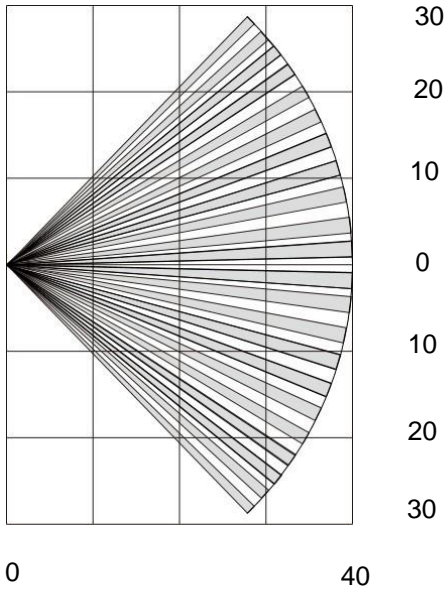

Sensor Disassembly

Use screwdriver to push inward the latch at the bottom of the detector (1.) On cover latch. (2.) Remove cover.

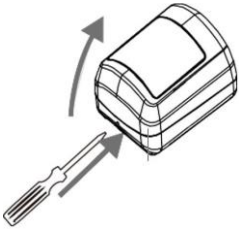

Detector Base Mounting

Identify necessary holes;

1. For wall mounting knock out hole covers.
2. For corner or 45 degree wall mounting, use drill to open at least two holes at base side depressions.

Wall mounting

Use screws to mount on wall or in corner.

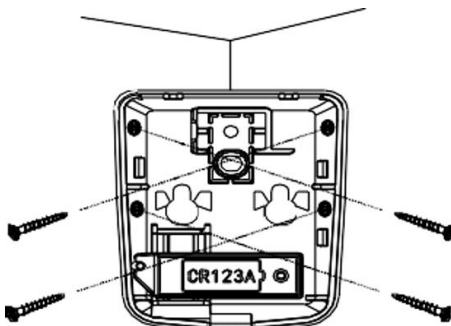

Battery Installation:

Place a CR123 battery in the battery holder. Be sure that the (+) is in the correct position.

Sensitivity setting:

With standard sensitivity, detection occurs in 3 to 5 steps. With high sensitivity, detection occurs in 2 to 4 steps.

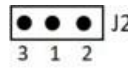

For Normal Sensitivity: Place jumper on 1-3 (3-5 steps)
For High Sensitivity: Place jumper on 1-2 (2-4 steps)

Programming

For complete programming information, refer to the specific control panel documentation.

To add the sensor to panel memory:

1. Place the panel in program mode.
2. Proceed to the section in programming for enrolling wireless sensors.
3. When the panel prompts enter the sensor ID# or trip the sensors tamper, to trip the tamper remove the motions cover.
4. Exit Program Mode.

Testing

Walk testing:

Enable the LED (J1 in its "LED" position). Walk across the monitored area (within the sensor's optical fields-of-view). The LED should turn ON (for Alarm) after about two to four normal steps. Each time the LED turns ON, wait for it to turn OFF. Then, wait 12 seconds before continuing the walk-test. When there is no motion in the monitored area, the LED should remain OFF.

Walk testing should be done to determine the sensor's actual coverage area. The edge of the coverage pattern is determined by the LED. This may change slightly depending upon the sensitivity setting. Walk test the unit from both directions to determine the pattern boundaries.

Caution: Excessive use of the walk test mode may reduce battery life. Use only for initial setup and maintenance testing.

Operation

3-minute lockout – to conserve battery life the detector has a 3-minute lockout between motion detections

Unless the jumper is installed the red LED will not light during motion detection.

Note: Leaving the LED jumper installed will greatly reduce the detectors' battery life.

Replacing the Battery

Battery life depends on how often the detector transmits signals, but is more dependent on the temperature of the installation environment. When the battery voltage gets low, the detector transmits a low battery signal to the panel. The panel then activates trouble beeps to notify the customer that the detector battery must be replaced. Pressing the status button identifies the sensor with the low battery.

Replace the battery immediately when this condition occurs, using the following battery: **Panasonic CR123A 3V**

Battery Disposal

The batteries used in this sensor are lithium batteries and are not reusable. Be sure to properly dispose of used lithium batteries according to your local hazardous waste disposal laws.

Specifications

Compatibility:	Honeywell, 2GIG 345MHz control panels
Power source:	1 CR123A 3V Battery
Tamper switch:	Sealed dome-contact
Sensitivity selectable:	2 or 3 events
Typical battery life:	4-6 years at 68°F
Transmitter frequency:	345 MHz
Operating temperature:	32°- 120°F (0°- 49° C)
Storage temperature range:	-30°-140° F (-34°- 60°C)
Maximum humidity:	90% Relative Humidity non-condensing
Dimensions:	3.19 x 2.4 x 1.7 inches (H x W xD)
Housing:	High impact ABS

FCC / IC Statement

This equipment has been tested and found to comply with the limits for a Class B digital device, pursuant to Part 15 of the FCC Rules. These limits are designed to provide reasonable protection against harmful interference in a residential installation.

This equipment generates, uses and can radiate radio frequency energy and, if not installed and used in accordance with the instructions, may cause harmful interference to radio communications. However, there is no guarantee that interference will not occur in a particular installation.

If this equipment does cause harmful interference to radio or television reception, which can be determined by turning the equipment off and on, the user is encouraged to try to correct the interference by one or more of the following measures:

- Reorient or relocate the receiving antenna.
- Increase the separation between the equipment and receiver.
- Connect the equipment into an outlet on a circuit different from that to which the receiver is connected.
- Consult the dealer or an experienced radio/TV technician for help.

This device complies with Industry Canada license-exempt RSS standard(s). Operation is subject to the following two conditions: (1) this device may not cause interference, and (2) this device must accept any interference, including interference that may cause undesired operation of the device.

Cet appareil est conforme avec Industrie Canada exempts de licence standard RSS (s). Son fonctionnement est soumis aux deux conditions suivantes: (1) cet appareil ne doit pas provoquer d'interférences et (2) cet appareil doit accepter toute interférence, y compris celles pouvant causer un mauvais fonctionnement de l'appareil.

In accordance with FCC requirements of human exposure to radio frequency fields, the radiating element shall be installed such that a minimum separation distance of 20 cm is maintained from the general population.

FCC: 2ABBZ-RF-ARPIR-345

IC: 11817A-RFARPIR345

This device complies with Part 15 of the FCC Rules. Operation is subject to the following two conditions: (1) This device may not cause harmful interference, and (2) this device must accept any interference received, including interference that may cause undesired operation. Changes or modifications not expressly approved by the party responsible for compliance could void the user's authority to operate the equipment.

This Class B digital apparatus complies with Canadian ICES-3B.

Cet appareil numérique de la classe B est conforme à la norme NMB-003 du Canada.

MANUFACTURER HEREBY DISCLAIMS ALL WARRANTIES AND REPRESENTATIONS, WHETHER EXPRESS, IMPLIED, STATUTORY OR OTHERWISE INCLUDING (BUT NOT LIMITED TO) ANY WARRANTIES OF MERCHANTABILITY OR FITNESS FOR A PARTICULAR PURPOSE WITH RESPECT TO THESE PRODUCTS AND ANY RELATED SOFTWARE. MANUFACTURER FURTHER DISCLAIMS ANY OTHER IMPLIED WARRANTY UNDER THE UNIFORM COMPUTER INFORMATION TRANSACTIONS ACT OR SIMILAR LAW AS ENACTED BY ANY STATE.

(USA only) SOME STATES DO NOT ALLOW THE EXCLUSION OF IMPLIED WARRANTIES, SO THE ABOVE EXCLUSION MAY NOT APPLY TO YOU. THIS WARRANTY GIVES YOU SPECIFIC LEGAL RIGHTS AND YOU MAY ALSO HAVE OTHER LEGAL RIGHTS THAT VARY FROM STATE TO STATE.

MANUFACTURER MAKES NO REPRESENTATION, WARRANTY, COVENANT OR PROMISE THAT ITS ALARM PRODUCTS AND/OR RELATED SOFTWARE (I) WILL NOT BE HACKED, COMPROMISED AND/OR CIRCUMVENTED; (II) WILL PREVENT, OR PROVIDE ADEQUATE WARNING OR PROTECTION FROM, BREAK-INS, BURGLARY, ROBBERY, FIRE; OR (III) WILL WORK PROPERLY IN ALL ENVIRONMENTS AND APPLICATIONS.